

Medford Township Public Schools

Sustainability is practiced for the future of our children.

Financial Savings is used to enhance curriculum initiatives.

Sustainability embedded in curricula ensures future generations are more aware and prepared to face the environmental and economic challenges that lie ahead.

Beginning Steps

- ① Develop a Green Team with district stakeholders.
- ② Identify key District issues and set goals and objectives.
- ③ Schedule meetings regularly to develop and improve strategies to meet identified goals.
- ④ Utilize Sustainable New Jersey Schools Website as a comprehensive resource.
- ⑤ Develop policies that align with District goals.

Developing a Plan

For facilities personnel, one of the greatest challenges can be getting buy in from Administration and the Board. Researching and developing a clear plan of what you intend to accomplish, including the costs and resources necessary to do so, will go much further than just concepts.

Find ways to spread the word

- Make Green Team initiatives a topic of discussion at faculty meetings.
- Develop a presentation for Administrative and BOE meetings.
- Inform members of your Business office about the many financial advantages sustainability practices offer. Grant opportunities also exist through Sustainable New Jersey Schools.

Outdoor Classroom

Funded by a \$10,000 Grant from Sustainable New Jersey Schools



Medford's Implementation for Cost Containment

- Nearly 70% of our schools electrical needs are generated by on site renewable energy. (solar)
- Four of our seven schools are heated and cooled using geothermal technology.
- Nations longest continuous user of renewable alternative fuels (biodiesel) for our entire Bus fleet.
- The district recently completed an (ESIP) that allowed for the completion of much needed capital improvement at no cost to local taxpayers.

	02-03	03-04	04-05	05-06	06-07	07-08	08-09	09-10	10-11	11-12	12-13	13-14	14-15	Avg
Electricity	455,443	499,606	674,280	774,034	835,670	809,911	878,320	738,842	819,745	674,402	802,037	679,071	679,305	716,974
Natural Gas	88,067	119,154	126,611	142,810	136,986	110,666	112,664	91,602	120,436	66,298	89,443	96,649	112,789	108,783
Total	543,510	618,760	800,891	916,844	972,656	920,577	990,984	830,444	940,181	740,700	891,480	775,720	792,094	825,757

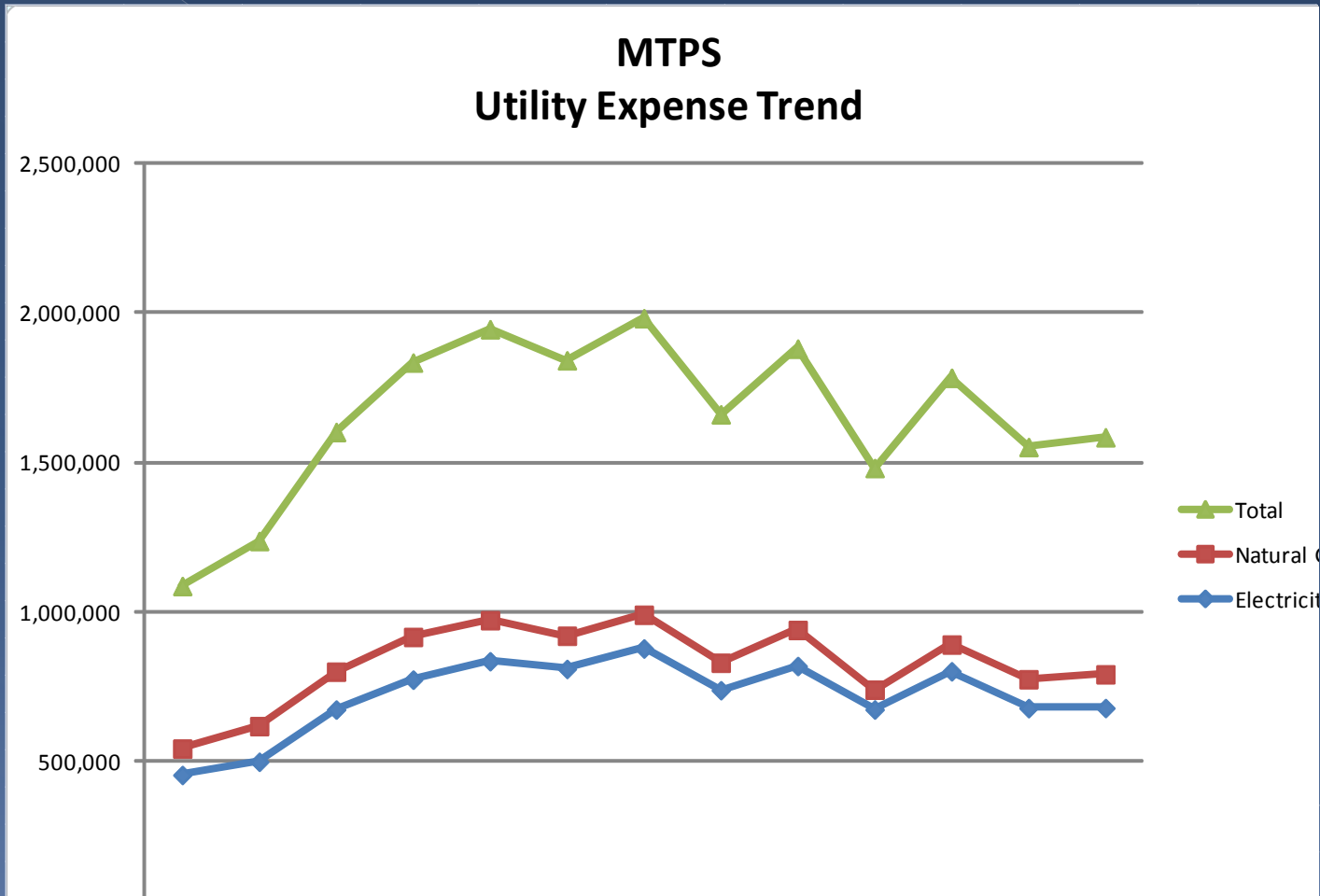

ESIP scope

Controls and Building Automation

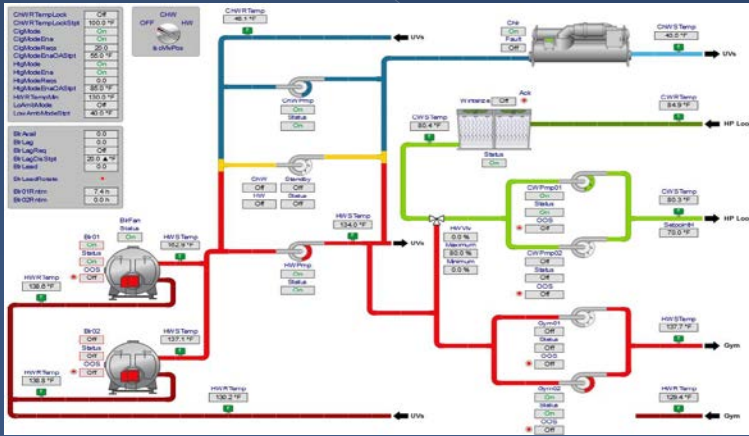

Envelope Sealing



LED Lighting



Manage By Measuring

- An Energy Management and Tracking software is essential for tracking progress, identifying trends and setting goals.
- MTPS uses Recourse Advisor as a comprehensive energy management tool.

Total Cost Breakout



Electric Power

Medford Township Public Schools



- \$101,140 : Memorial Middle School
- \$94,496 : Taunton Forge Elementary
- \$33,164 : Chairville Elementary Sch
- \$31,657 : Allen Elementary School
- \$30,812 : Kirby's Mill Elementary S
- \$42,187 : Other

Total : \$333,455

Start Date: August, 2015

End Date: August, 2016

Go

Upcoming Contract Expirations



There are no contracts expiring within the next 90 days.

Recent Documents



Title	Category	Date
Medford SSR.pdf	Misc	1/21/2015
Medford SSR.pdf	Misc	1/21/2015
Medford SSR.pdf	Misc	1/21/2015
Medford SSR.pdf	Misc	1/21/2015
Medford SSR.pdf	Misc	1/21/2015

Invoice Participation



Medford Township Public Schools

Services: All

*In order to accurately report metrics and savings, Schneider Electric requires a high percentage of participation.

95%

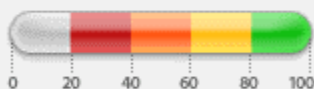

Start Date: August, 2015

End Date: July, 2016

Go

Cost Usage Monthly



Electric Power

kWh

Chart

Table

Medford Township Public Schools

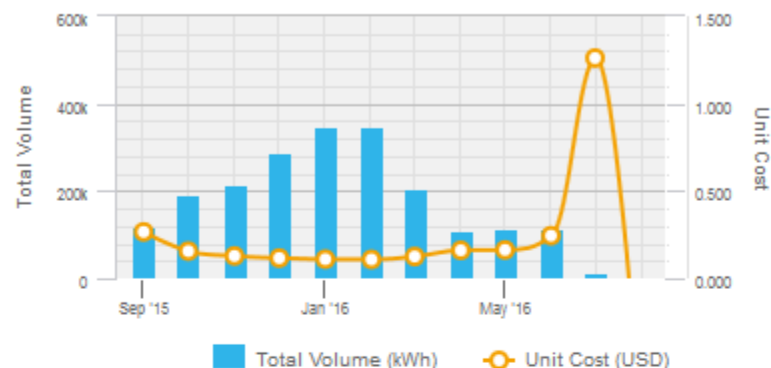

Start Date: September, 2015

End Date: August, 2016

Go

Market News



Date	Title	State
10/4/2016	Rate Change Notification - New Jersey Natural Gas, NJ	NJ
9/30/2016	Rate Change Notification - Orange & Rockland NJ	NJ
8/31/2016	Rate Change Notification - Atlantic City Electric, NJ	NJ
4/15/2016	IPCC Developing 1.5C Climate Change Report	Multiple
3/28/2016	Atlantic City Electric, NJ	NJ

Variance



Data Type: Total Cost

Medford Township Public Schools

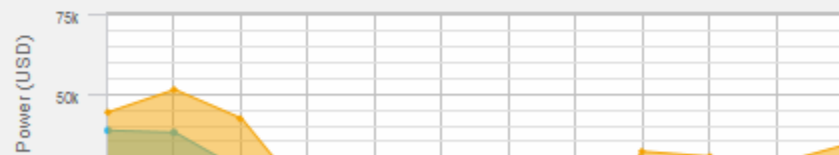

Questions..

John Gallagher

Operations and Maintenance Supervisor
Medford Township Public Schools

jgallagher@Medford.k12.nj.us

609-953-5841 ext. 1507